

# HX 3.5 Analog Controller & MPX Input

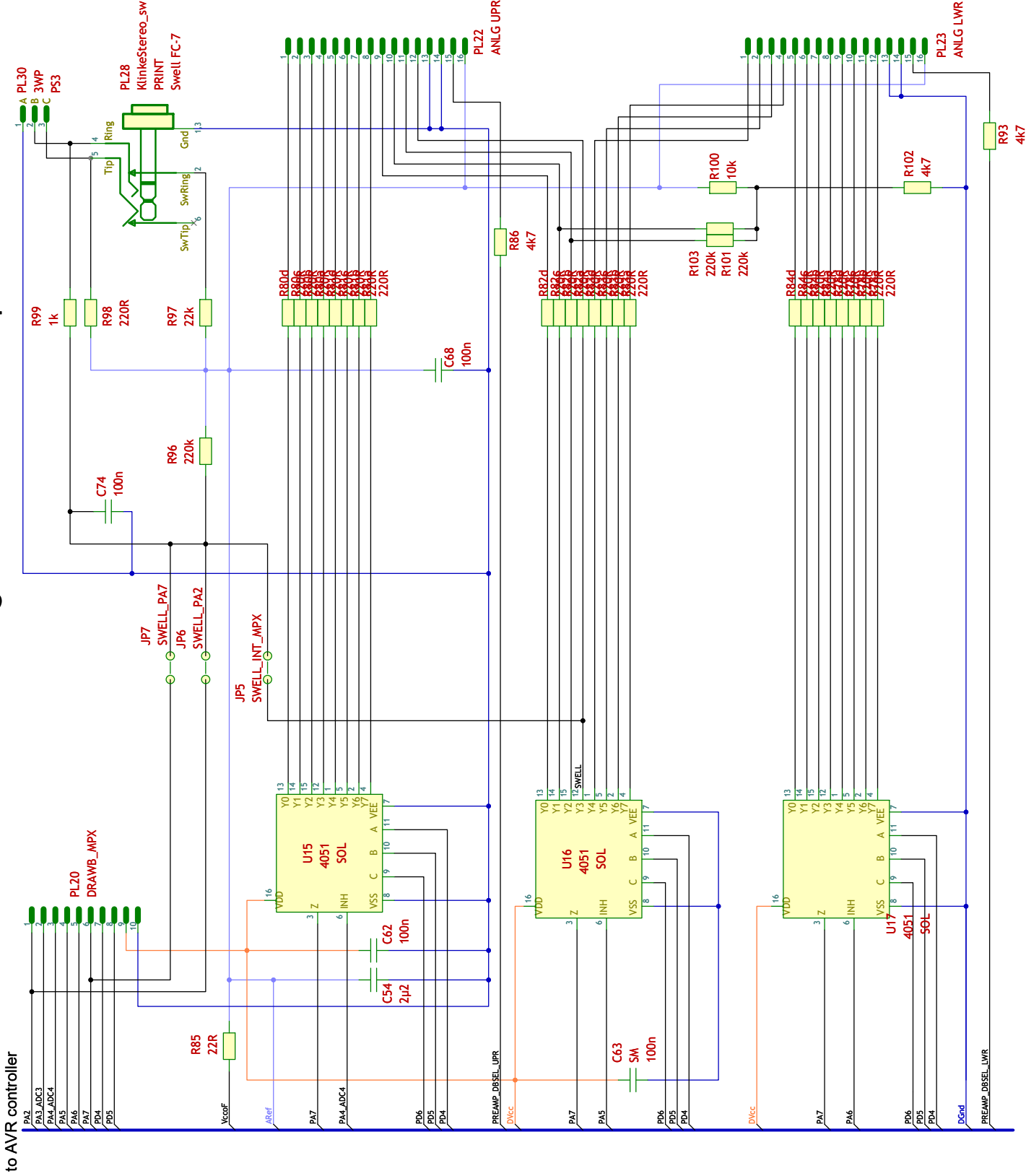

- Analog Controller A Header Pins
- Upper Drawbars
- 1 - Drawbar 16
  - 2 - Drawbar 5 1/3
  - 3 - Drawbar 8
  - 4 - Drawbar 4
  - 5 - Drawbar 2 2/3
  - 6 - Drawbar 2
  - 7 - Drawbar 1 5/9
  - 8 - Drawbar 1 1/3
  - 9 - Drawbar 1
  - 10 - Tone Pot
  - 11 - Leslie Volume Pot
  - 12 - Aux Analog (Swell Pedal)
  - 13, 14 - Drawbar Gnd
  - 15, 16 - Drawbar End V+ (Reference)

- Analog Controller B Header Pins
- Lower and Bass Drawbars
- 1 - Drawbar 16
  - 2 - Drawbar 5 1/3
  - 3 - Drawbar 8
  - 4 - Drawbar 4
  - 5 - Drawbar 2 2/3
  - 6 - Drawbar 2
  - 7 - Drawbar 1 5/9
  - 8 - Drawbar 1 1/3
  - 9 - Drawbar 1
  - 10 - Drawbar Bass 16
  - 11 - Drawbar Bass 8
  - 12 - Drawbar/Pot Bass Sustain
  - 13, 14 - Drawbar Gnd
  - 15, 16 - Drawbar End V+ (Reference)